

CORDOLO

8X25X100

CERTIFICAZIONE CAM *SU RICHIESTA* 

Requisiti tecnici CAM: I prodotti soddisfano i requisiti CAM di cui al decreto 23/06/22 del ministero della transizione ecologica

Scheda 1 D

INFO PRODOTTO:

Dimensioni modulari (S x H x L) **mm 80 x 250 x 1000**

Peso **± 41,5 Kg/cad**

Fabbisogno **1pz/ML**

Metodo di incastro **Giunto Maschio / Femmina**

Densità impasto **≥2200 kg/m³**

Colorazioni: **Grigio** (altri colori su richiesta)



IMBALLO/FINITURA/COLORI

Tipo Imballo: **Pallets**

Finitura: **Normale o Quarzo**

Quantità imballo: **44 pz**

Peso imballo: **± 1826 Kg**

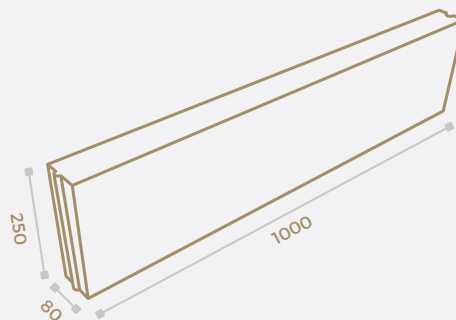

CARATTERISTICHE TECNICHE (UNI EN 1340)

Resistenza caratteristica a flessione: **Classe 1 - Marcatura S ≥ 3,5 Mpa**

Resistenza allo scivolamento: **Soddisfacente**

Resistenza abrasione: **Classe 3 - Marcatura H ≤ 23 mm**

Assorbimento acqua per immersione: **Classe 2 - Marcatura B ≤ 6%**

Resistenza gelo/disgelo: **Classe 3 - Marcatura D ≤ 1 Kg/m²**

Emissione amianto: **Nessuna**

CERTIFICAZIONI E PRESTAZIONI



Resistente
all'abrasione



Prestazioni Eco



Resistente al
gelo/disgelo



UNI EN
1338



Valente Srl di Pietro Valente | C/da Patriarca 3 - 87040 San Lorenzo del Vallo (CS)

Tel. 0981 954840  | Email. valentesrl@gmail.com | www.valentesrl.com